

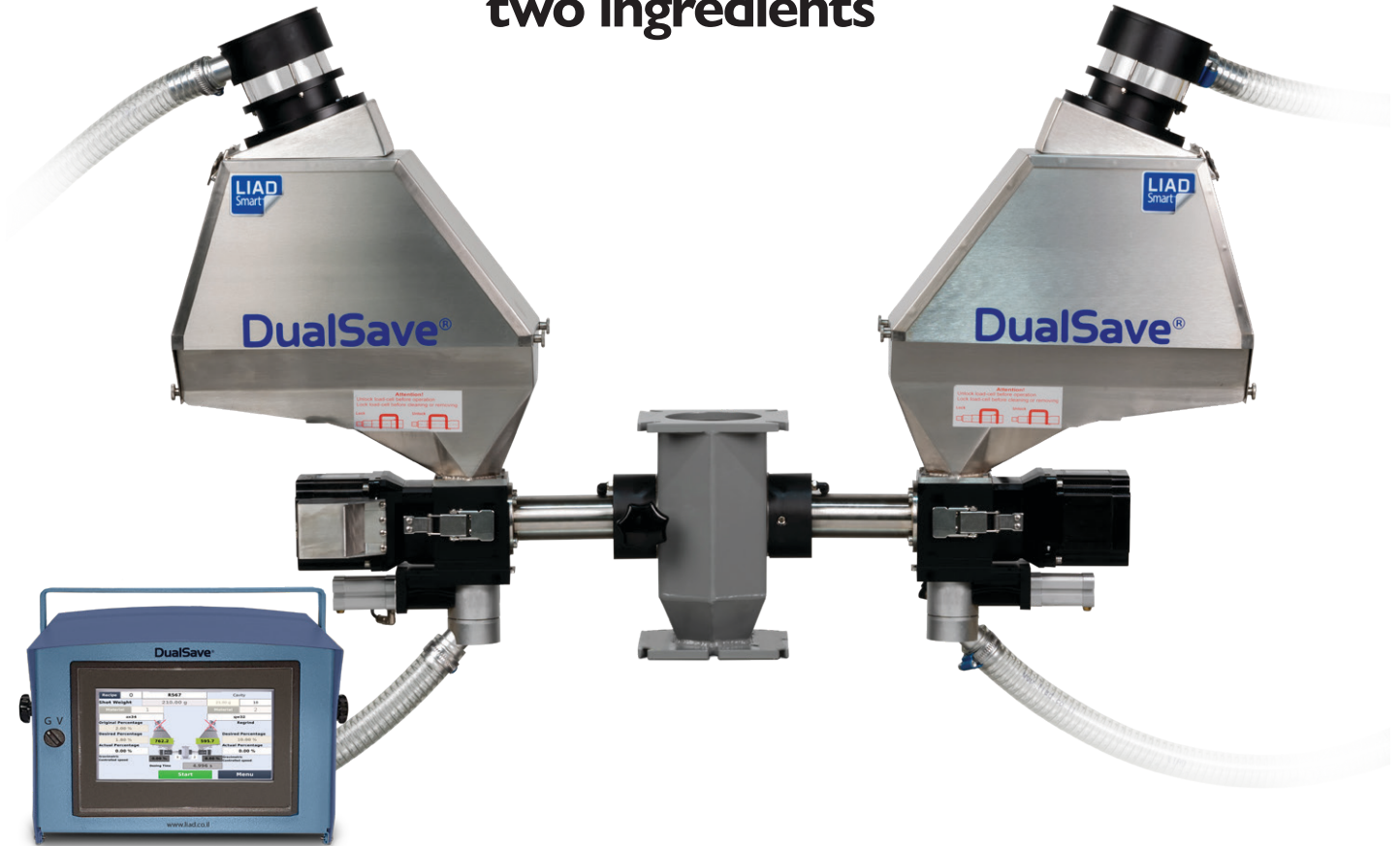

DualSave®

Ultra-precise dosing for
two ingredients



Ideal for precise integration of
masterbatch, additives, and regrind

Automatically adjusts colorant
dosing when using regrind

AMPACET
Plastics Reimagined™



Smart technology that simplifies dosing of two ingredients

DualSave precision dosing system uses a single control to regulate two feeders connected to a single neckpiece. DualSave assures consistent and precise operation for either gravimetric or volumetric feeding to significantly reduce rejects, improve the quality of the final product, and save money.

- No more employee calculations and adjustments between runs
- Eliminates over-dosing of expensive color masterbatches when using regrind



DualSave with 3L gravimetric hoppers and optional Venturi loaders.



DualSave with 6L volumetric hopper and 3L gravimetric hopper with optional Venturi loaders.

DualSave advantages

- Smart Clean self-cleaning feature
- Unparalleled accuracy and precision
- Easy to use intuitive control unit
- Improved quality of final product, fewer rejects
- Stores up to 500 recipes, saves set up time
- Compensates MB amount when using regrind
- Economical alternative to batch blenders
- DualSave can be incorporated with LIAD Smart PowderSave® allowing powders and regrind or MB to be fed using one PLC

Multiple applications

- Injection molding
- Extrusion
- Extrusion blow molding

Available with volumetric or gravimetric hoppers

- Volumetric hoppers-6, 12, 20 L capacities
- Gravimetric hoppers-3, 5, 10 L capacities

DualSave Exclusive Automatic Compensation Feature



The DualSave controller contains a built-in compensation feature that can be used when one of the hoppers is volumetric and feeding regrind and the other hopper is feeding masterbatch either gravimetrically or volumetrically. Since the regrind already contains color or additives, you can reduce the amount of colorant or additive fed from the other hopper. This exclusive DualSave feature reduces human error to enhance quality and

provide substantial production cost savings. For example, if a recipe calls for 5% masterbatch in one hopper and 20% regrind in the other hopper, DualSave automatically reduces the masterbatch percentage to 4%. Increasing the regrind to 40% reduces the masterbatch to 3%.

A sensor in the regrind hopper returns the setting to its original percentage when there is no more regrind.

Smart Clean Feature

Our latest enhancement in DualSave is the SmartClean option that automates the cleaning process when changing materials. With a simple push of a button, this feature uses compressed air to evacuate the material from inside the hopper and feed screw automatically,

ensuring operator safety and minimizing downtime. With DualSave's self-cleaning SmartClean option, manufacturers can achieve higher productivity, reduce manual cleaning efforts, improve operator safety, and maintain the highest production standards.

DualSave Specifications

Feature	Specification
Hopper Volume	3/5/10 liter gravimetric 6/12/20 liter volumetric
Output range	.44-220 lb/hr (0.2-100 kg/hr) with gravimetric hopper .44 -440 lb/hr (0.02-200 kg/h with volumetric hopper
Motor	Powerful step motor
Display	7" color touch screen
Input signals – Injection molding	Dry contact for synchronization with plasticization cycle, optional dry contact for synchronization with injection cycle
Input signals – Extrusion	Dry contact for synchronization with extruder on/off operation, synchronization using analog input 0-10V or 24V digital tachometer
Input signals – Blow molding	Dry contact for synchronization with extruder on/off operation, dry contact for synchronization with mold cycle
Recipes	500
Communication	Modbus TCP/IP Included in injection molding and blow molding applications, optional in extrusion application
Load cell	15 kg for 3 or 5 liter volume, 30 kg for 10 liter volume Temperature compensated
Loader	Optional automatic integral Venturi vacuum loader or single phase motor loader
Mounting and feeding	By neckpiece adapter, directly into the machine throat
Alarm output	N/O or N/C dry contact 0V, optional 24V/30mA max.
Power	100-240v, 200Vv, 50/60hz

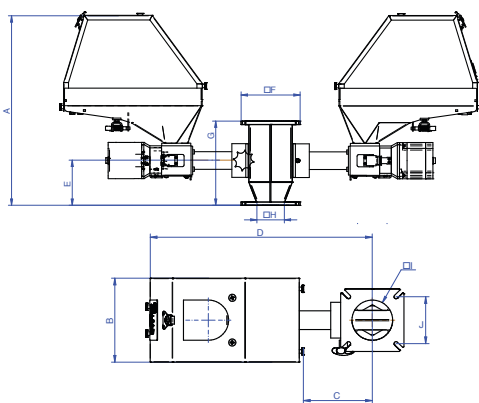

Dimension	Grav.			Vol.		
	3 Lt.	5 Lt.	10 Lt.	6 Lt.	12 Lt.	20 Lt.
A in [mm]	17.7 [450]	19.7 [500]	20.9 [530]	15.1[385]	17.9 [455]	20.5 [520]
B in [mm]	7.3 [186]	8.3 [210]	9.8 [250]	7.6 [194]	12.2 [310]	11.2 [285]
C in [mm]	5.9 [150]	5.9 [150]	5.0 [128]	6.3 [159]	6.3 [161]	5.3 [135]
D in [mm]	19.3 [490]	19.3 [490]	21.1[537]	19.6 [498]	21.6 [550]	25.9 [658]
E in [mm]	4.2 [106]	4.2 [106]	3.7 [95]	4.2 [106]	4.2 [106]	3.7 [95]
F in [mm]	5.5 [140]	5.5 [140]	5.5 [140]	5.5 [140]	5.5 [140]	5.5 [140]
G in [mm]	7.9 [200]	7.9 [200]	7.9 [200]	7.9 [200]	7.9 [200]	7.9 [200]
H in [mm]	1.6 [40] (2.6 [65])	1.6 [40] (2.6 [65])	2.8 [70] (5.0 [128])	1.6 [40] (2.6 [65])	1.6 [40] (2.6 [65])	2.8 [70] (5.0 [128])
I in [mm]	3.5 [90]	3.5 [90]	5.0 [128]	3.5 [90]	3.5 [90]	5.0 [128]
J in [mm]	4.1 [105]	4.1 [105]	4.1 [105]	4.1 [105]	4.1 [105]	4.1 [105]

About LIAD Smart

Ampacet LIAD pioneered the single component gravimetric feeder for injection molding machines and is the leading developer of innovative feeders, blenders and real-time quality control color solutions for the plastics industry.



Look for the LIAD Smart label to ensure the highest quality accuracy.

For more information and to schedule a free demo, email LIADSmart@ampacet.com

The information and recommendations contained in this document are based upon data collected by Ampacet and believed to be correct. However, no warranty of fitness for use or any other guarantees or warranty of any kind, expressed or implied, is made to the information contained herein, and Ampacet assumes no responsibility for the results for the use of products and processes described herein. No liability whatsoever shall attach to Ampacet for any infringement of the rights owned or controlled by a third party in intellectual, industrial or other property by reason of the applications, processing or use of the aforementioned information or products by the buyer.

AMPACET
Plastics Reimagined™

World Headquarters: 660 White Plains Road, Tarrytown, NY 10591-5130
Email: LIADSmart@ampacet.com Web: ampacet.com/LIADSmart

