



BatchSave[®]

Gravimetric Batch Blender

Precise and convenient blending
More than imagined, better than expected



BatchSave is a multi-ingredient gravimetric batch blending system. The system prepares a batch in a weighing hopper, metering each material by high resolution load cells and filling each ingredient in turn according to a predefined recipe, then blend it in a mixer to create homogeneous blend. Thanks to LIAD's unique control algorithm, all that user needs to do is solely input blend batch weight and mixing ratio of each ingredient in %, the rest of the job is performed by the control algorithm.

Working

Filling into weighing hopper

When machine starts working by pressing Start button the system retrieves the preset recipe and starts feeding the raw materials in material hoppers in turns by the pre-determined sequence into the weighing hopper.

Mixing and discharging

At the end of metering all ingredients process, the materials are discharged down to the mixer, via weighing hopper shut-off valve. Once mixing is completed the mixed materials are discharged from the mixer using mixing chamber shut-off valve.

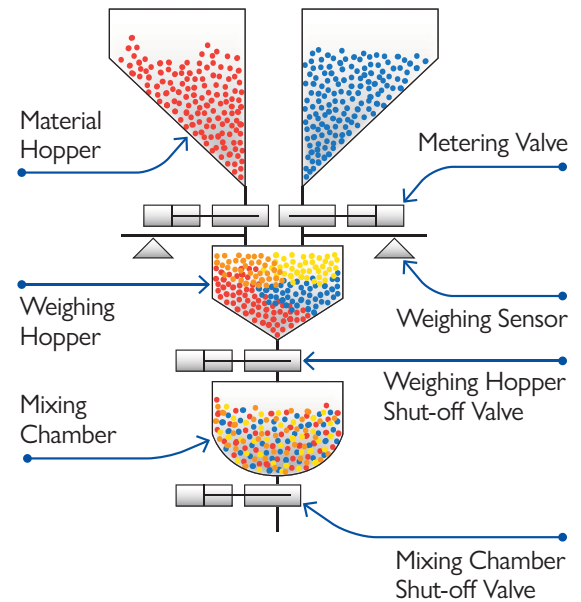

Flexibility of applications in production process

Diversity in composition of numbers of material

BatchSave has 4 up to 8 channels, each channel contains one material. The feeding of each material can be normal or with pulsing. During operation, the BatchSave "learns" the material in each channel and changes the operation of each channel according to the material characteristics.

Mounting locations

BatchSave can be installed directly on the production machine's throat so the blend falls down directly to the production machine, or on the floor using a frame stand so the blend falls down to material storage tank, and from there it is conveyed to one or more production machines.



Machine mounting



Floor mounting

Features

Shorter batch cycle time

BatchSave uses precise and quick controlling pneumatic metering valve enables short batch cycle time for micro ratio of blending ingredients.

Higher accuracy and more reliable weighing assurance

- Equipped and employing weighing tools and control algorithm assures higher and more reliable accuracy in weighing process.
- Primary, secondary or special metering valves selectively combined based on mixing ratio, materials kind and type.
- 2 Load cells equipped (1 for BS-40).
- Normal and pulsing filling into weighing hopper.
- Split a material to two halves applicable.
- Rational self-correction LIAD algorithm.
- Accuracy between $\pm 0.1\%$ to $\pm 0.3\%$ except extraordinary material process.

Homogeneous blend

LIAD's state-of-art mixer blade profile enables constantly homogeneous blend in mixing chamber. Capable of handling irregular size or film/sheets scrap BatchSave can accommodate irregular granulated material, within 12x12x12 mm in size, using optional LIAD special valve with optional built-in bridge breaker device preventing material clogging and rat hole in the neck of hopper.

Magnet base

Mounted on machine material throat under BatchSave this unit helps detecting metal particles contained in blend material to prevent severe damages on the products, molds or machine screw.

Easy replacement and cleaning

Rigid but ideal mechanical structure offers most convenient cleaning of each compartment like material hoppers, weighing chamber and mixer upon changing ingredient materials to use.

Operator-oriented HMI color touch screen

On a single main screen can be monitored all process from filling materials through to final discharging the blend into machine throat or material tank. Also can the operation status of each compartment be checked at a look.

This screen leads the operator easily to access some useful function including recipe management and further system setting menu by touching the relevant button.

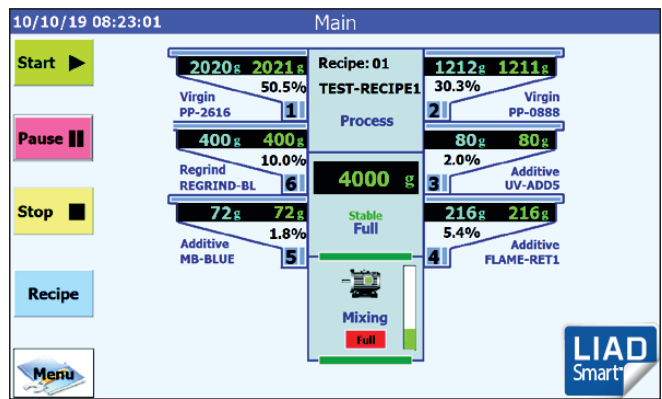

Recipe management

- Convenient to edit new recipe or update working recipe when operator changes parameter from the stored recipe in accordance with most appropriate parameter mix acknowledged during the specific production.
- Recipe management has other advanced features such as split material to half at the beginning and half at the end, or set additive ratio to the complete batch or to the virgin only.

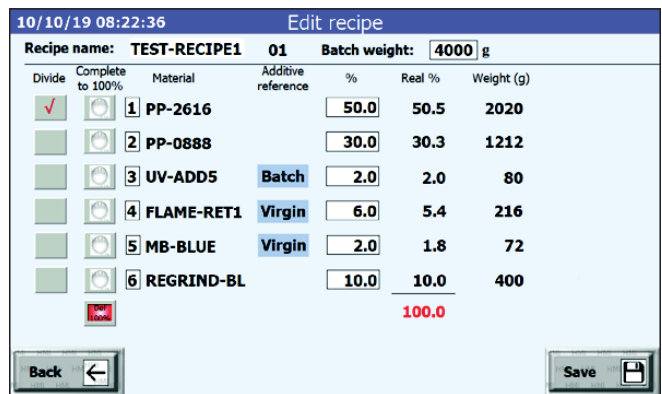

Self Correction function

The system learns the weight of the material in the air after metering valve closed and takes it into calculation of actually true weight value. If there is a deviation between the actual material in the air and the calculated material in the air, then the calculated value of the material in the air is updated.

Data communication

BatchSave uses Profinet communication protocol.
Other communication protocols are available upon request.

Flexible vacuum loading system interface

The system can work in one of two working modes, either as a part of a main vacuum system, or as an isolated vacuum system by using a local vacuum pump. In both working modes, BatchSave control all the loaders by allocating the loading time and operating filter clean for each of the loaders.

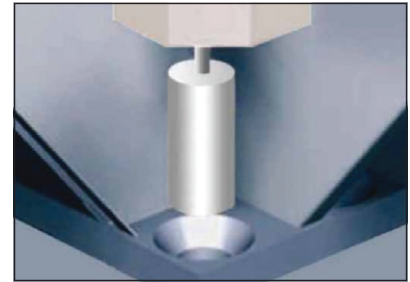

Metering valve

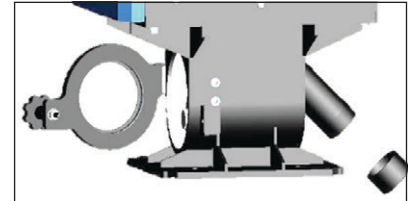

Magnet base



Easy removable hopper for BS-40 model only



Quick emptying outlet for BS-200 and above model



Easy removable weighing chamber



Specifications

Model	Number of channels	Primary metering valves ⁽¹⁾	Secondary metering valves ⁽²⁾	Load cells	Max. batch weight (kg)	Mixing motor ⁽³⁾ (kW)	Max. throughput ⁽⁴⁾ (kg/hr)
BS-40-4	4	3	1	1	1	0.25	40
BS-200-4	4	3	1	2	3	0.25	200
BS-600-4	4	3	1	2	8	0.55	600
BS-600-6	6	4	2				400
BS-1200-4	4	3	1	2	12	0.55	1200
BS-1200-6	6	4	2				900
BS-2000-4	4	3	1	2	18	0.55	2000
BS-2000-6	6	4	2				1600
BS-2000-8	8	5	3				1200
BS-3000-4	4	3	1	2	40	0.75	3000
BS-3000-6	6	4	2				2500
BS-3000-8	8	5	3				2000

The above specifications are subject to change for quality improvement without prior notice.

- (1) Primary metering valve is most suitable for mixing ratio 5% and above, and material granule size within 6x6x6 mm of evenly regular shape.
- (2) Secondary metering valve is most suitable for mixing ratio between 0.5%-5%, and material granule size within 4x4x4 mm of evenly regular shape.
 - (Optional) Micro metering valve is available for mixing ratio between 0.2%-0.5% and material granule size within 4x4x4 mm of evenly regular shape.
 - (Optional) Special metering valve is available for sheet scrap and irregular shape of size within 12x12x12 mm.
- (3) Mixing motor electricity: 3Ø, 400VAC, 50-60Hz.
- (4) Max. throughputs data is based on material characteristics of bulk density 0.8 gr/cm³, regular granule shape of 3-4 mm in size and sufficient flow drops. This data is subject to change in accordance with material characteristics in actual use.

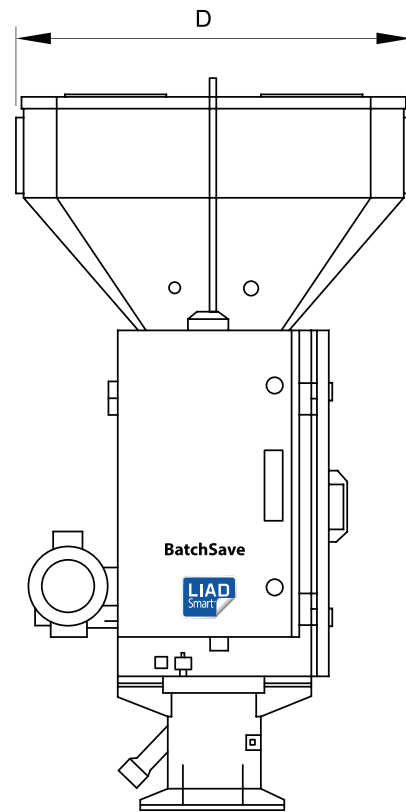
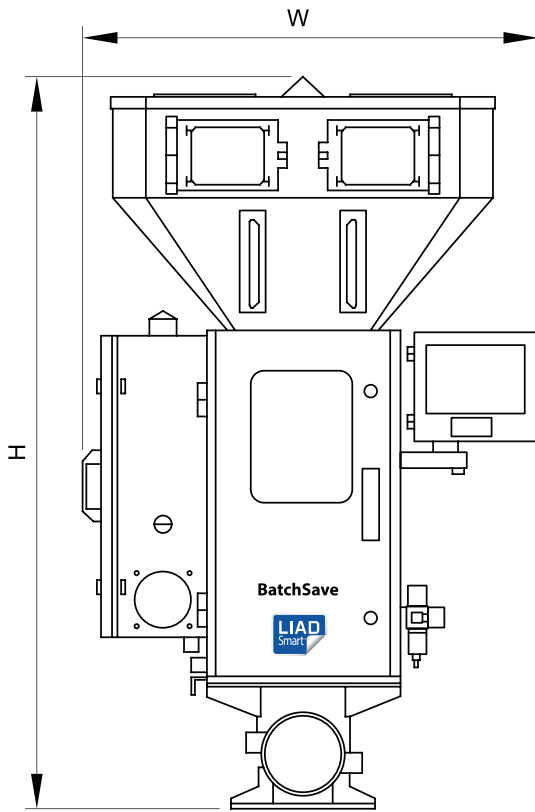

Main Body

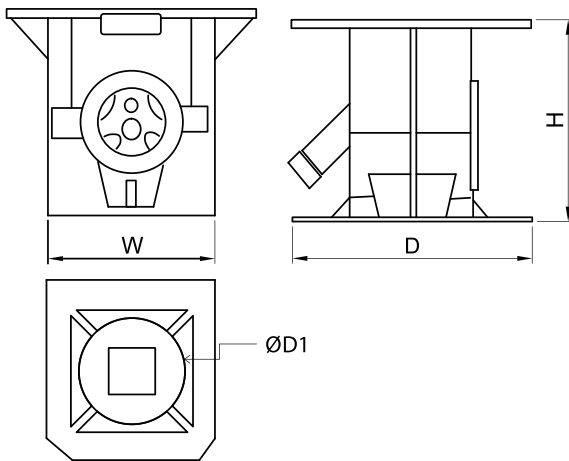

Magnetic Base

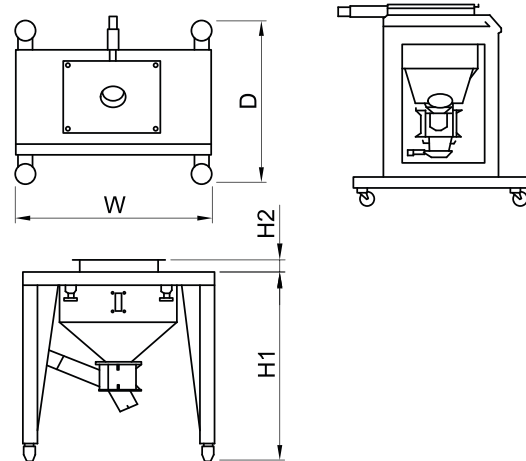

Moving Stand

The appearances of the above may vary in each model.

Part		BS-40	BS-200	BS-600	BS-1200	BS-2000	BS-3000
Main Body	H (mm)	1110	1300	1445	2398	2800	3375
	W (mm)	770	810	905	940	1110	1695
	D (mm)	675	735	785	1023	1180	1695
Magnetic Base	H (mm)	244	213	250	-	-	-
	W (mm)	220	250	280			
	D (mm)	220	250	280			
	Mouth Ø (mm)	160	200	220			
Moving Stand	H1 (mm)	713	880	885	900	1000	1075
	Pneumatic Plate H2 (mm)	50	50	60	60	65	70
	W (mm)	654	724	814	930	1060	1240
	D (mm)	600	800	800	930	1000	1240
Machine Weight (kgs) w/o stand		115	135	160	-	-	-
Machine Weight (kgs) with stand		135	170	220	400	500	850

The above specifications are subject to change for quality improvement without prior notice.

About LIAD Smart

Ampacet LIAD pioneered the single component gravimetric feeder for injection molding machines and is the leading developer of innovative feeders, blenders and real-time quality control color solutions for the plastics industry.



Look for the LIAD Smart label to ensure the highest quality accuracy.

For more information and to schedule a free demo,
email LIADSmart@ampacet.com

The information and recommendations contained in this document are based upon data collected by Ampacet and believed to be correct. However, no warranty of fitness for use or any other guarantees or warranty of any kind, expressed or implied, is made to the information contained herein, and Ampacet assumes no responsibility for the results for the use of products and processes described herein. No liability whatsoever shall attach to Ampacet for any infringement of the rights owned or controlled by a third party in intellectual, industrial or other property by reason of the applications, processing or use of the aforementioned information or products by the buyer.



AMPACET

Plastics Reimagined™

World Headquarters: 660 White Plains Road, Tarrytown, NY 10591-5130
Email: LIADSmart@ampacet.com Web: ampacet.com/LIADSmart